

get started

**INSTANT POT® PRO CRISP
MULTI-COOKER + AIR FRYER**

USER MANUAL

Instant Pot

Welcome

to your new Instant Pot Pro Crisp!

This Instant Pot® Pro Crisp multi-cooker can help you cook healthy, delicious meals more easily and in less time. We hope you fall in love with Instant Pot cooking, and enjoy it in your kitchen for years to come!

Get started with your new Instant Pot!



⚠️ WARNING

Before using your new appliance, read all instructions, including the Important Safeguards. Failure to follow the safeguards and instructions may result in personal injury and/or property damage.

CONTENTS

Important safeguards	2
What's in the box	8
Using your Instant Pot Pro Crisp	11
Initial setup	15
About pressure cooking	17
Using the pressure cook lid	18
Using the air fry lid	22
Pressure Cook	24
Steam	26
Sauté	28
Slow cook	30
Sous Vide	32
Keep Warm	34
Air fry	36
Roast	38
Bake	38
Broil	39
Dehydrate	39
Maintenance	40
Cleaning	47
Troubleshooting	49
Error Codes	53
Replacement parts	55
Learn more	56
Warranty	57
Notes	59

IMPORTANT SAFEGUARDS

⚠ WARNING

Failure to follow safety instructions may result in personal injury and/or property damage and may void your warranty.

READ ALL INSTRUCTIONS

Before using your new appliance, please read all instructions, including the Safety Information below. Keep this manual for reference.

Placement

- **DO** place the appliance on a countertop only. Always operate the appliance on a stable, non-combustible, level surface.
- **DO** make sure all parts are dry and free of food debris before placing the inner cooking pot on the cooker base.
- **DO NOT** place the appliance or power cord on or close to a gas or electric stovetop or oven. **NEVER** use the appliance on your stove.
- **DO NOT** use the appliance near water, an external heat source or flame.
- **DO NOT** use outdoors. Keep out of direct sunlight.
- **DO NOT** place on anything that may block the vents on the bottom of the appliance.

General Use

The removable inner cooking pot is extremely hot during use and can be extremely heavy when full of ingredients.

- **DO** use oven mitts when handling the inner cooking pot and removing accessories.
- **DO** place hot accessories on a heat-resistant surface or cooking plate.
- **DO** use care when lifting the cooking pot from the cooker base to avoid burn injury.
- **DO** use extreme caution when the cooking pot contains hot food, hot oil or other hot liquids.
- **DO** use only the Instant Pot lid or lids that came with this cooker base. Using any other pressure cooker lids may cause personal injury and/or property damage. Only use the appliance's side handles when carrying or moving.

⚠ WARNING

Failure to follow safety instructions may result in personal injury and/or property damage and may void your warranty.

- **DO NOT** use the appliance without the removable inner cooking pot installed.
- **DO NOT** touch the appliance's hot surfaces, or any accessories during or immediately after cooking because they will be hot. Only use the appliance's side handles for carrying or moving.
- **DO NOT** use this appliance for deep frying or pressure frying with oil.
- **DO NOT** move the appliance while it is in use and use extreme caution when disposing of hot grease.
- **DO NOT** allow children or persons with reduced physical, sensory or mental capabilities to operate this appliance. Close supervision is necessary when any appliance is used by or near children and persons with reduced physical, sensory or mental capabilities. Children should not play with this appliance.
- **DO NOT** use the appliance for anything other than household use. It is not intended for commercial use.
- **DO NOT** leave the appliance unattended while in use.
- **DO NOT** store any item on top of the appliance. A fire may occur if the appliance is covered or touching flammable material, including curtains, draperies, walls, and the like.

Pressure Cooking

This appliance cooks under pressure. Allow the appliance to depressurize naturally or release all excess pressure before opening.

Failure to follow these instructions may result in burns, personal injury and/or property damage.

- **DO** make sure the appliance is properly closed before operating.
- **DO** check that the steam release valve is installed properly.
- **DO** use the pressure cooking lid or Ultimate lid when pressure cooking.
- **DO** turn the appliance off if steam escapes from the steam release valve and/or float valve in a steady stream for longer than 3 minutes. If steam escapes from the sides of the lid, turn the appliance off. Once steam stops, pressure is released and the cooker has cooled, carefully make sure the sealing ring is properly installed.
- **DO** ensure the sealing ring is in good condition and installed properly.
- **DO** check the steam release valve, steam release pipe, anti-block shield and float valve for clogging before use.

⚠ WARNING

Failure to follow safety instructions may result in personal injury and/or property damage and may void your warranty.

- **DO NOT** remove the lid with unprotected hands.
- **DO NOT** attempt to force the lid off the Instant Pot cooker base.
- **DO NOT** move the appliance when it is pressurized.
- **DO NOT** cover or obstruct the steam release valve and/or float valve with cloth or other objects.
- **DO NOT** attempt to open the appliance until it has depressurized, and all internal pressure has been released. Attempting to open the appliance while it is still pressurized may lead to sudden release of hot contents and may cause burns, personal injury and/or property damage.
- **DO NOT** place your face, hands or exposed skin over the steam release valve or float valve when the appliance is in operation or has residual pressure, and do not lean over the appliance when removing the lid.

Overfill During Pressure Cooking

Overfilling may cause a risk of clogging the steam release pipe and valve, developing excess pressure.

- **DO NOT** fill the inner cooking pot over the line labeled 'PC MAX' or 'Max PC Fill'.
- **DO NOT** fill the inner cooking pot over the line labeled '1/2' when cooking foods that expand during cooking such as rice, dried beans or dried vegetables.
- **DO** be aware that certain foods, such as applesauce, cranberries, pearl barley, oatmeal or other cereals, split peas, noodles, macaroni, rhubarb, or spaghetti can foam, froth and sputter, and clog the steam release pipe and valve. **DO NOT** fill the inner cooking pot over the line labeled '1/2' when cooking these foods.
- **DO NOT** place oversized foods into the inner cooking pot as they may cause risk of fire, personal injury and/or property damage.

Air Frying Cautions

When the air fryer is in operation, hot air is released through the air vents. Keep your hands and face away from the air vents and take extreme caution when removing hot accessories from the appliance.

Failure to do so may result in personal injury and/or property damage.

⚠ WARNING

Failure to follow safety instructions may result in personal injury and/or property damage and may void your warranty.

While cooking, the internal temperature of the appliance reaches several hundred degrees. To avoid personal injury, never place unprotected hands inside the appliance until it has cooled to room temperature.

- **DO** use the included inner cooking pot when using the air fryer or Ultimate lid.
- **DO** use extreme caution when using containers made of materials other than glass or metal. Failure to do so may result in personal injury, fire and/or property damage.
- **DO** use extreme caution when removing the inner cooking pot, air fry basket or cooking tray, or disposing of hot cooking residue.
- **DO NOT** use a ceramic-coated or stoneware pot for air frying.
- **DO NOT** cover or block the vents while the air fryer is operating. Doing so will prevent even cooking and may cause damage to the appliance. Leave at least 5 in / 13 cm of space around the air fryer when in use.
- **DO NOT** use this appliance for deep frying foods.
- **DO NOT** pour oil into the cooking container. Using excess cooking oil could cause fire and result in personal injury and/or property damage.
- **DO NOT** use pressurized, aerosol oil sprays, since they contain chemicals that can damage the non-stick finish of the cooking tray. If needed, spray food lightly with oil with a high smoke point (such as refined avocado oil, safflower oil, refined sunflower oil, refined peanut oil, canola oil and refined coconut oil) from a non-aerosol, pump-style cooking spray before placing in the basket.
- **DO NOT** use this appliance for making popcorn.
- Should the unit emit black smoke during use, press **Cancel** and unplug the appliance immediately. Wait for smoking to stop before removing the lid, then clean thoroughly. For further information refer to 'Troubleshooting'.

Overfill During Air Frying

- **DO NOT** overfill the unit when air frying. Overfilling may cause food to contact the heating element, which may result in personal injury, fire, and/or property damage. When using an air fry tray or cooking tray, only place food in a single layer and do not stack. When using an air fry basket, do not fill more than 3/4 full. Best air frying results require air circulating through the food.
- **DO NOT** allow food to contact the heating element.

⚠ WARNING

Failure to follow safety instructions may result in personal injury and/or property damage and may void your warranty.

Accessories

- **DO** use only accessories or attachments authorized by Instant Pot Brands. The use of parts, accessories or attachments not recommended by the manufacturer may cause a risk of electric shock or other personal injury, fire and/or property damage.
- **DO** use only an authorized Instant Pot inner cooking pot to reduce the risk of pressure leakage.
- **DO** only replace the sealing ring with an authorized Instant Pot sealing ring to prevent personal injury, property damage, and/or damage to the appliance.
- **DO NOT** use the included accessories in a microwave, toaster oven, convection or conventional oven, on a ceramic, electric or gas cooktop, or with an outdoor grill.

Care and Storage

- **DO** let the appliance cool to room temperature before cleaning or storage.
- **DO NOT** store any materials, other than the inner cooking pot, in the cooker base when not in use.
- **DO NOT** place any combustible materials in the cooker base, such as paper, cardboard, plastic, Styrofoam or wood.
- **DO NOT** clean the appliance with metal scouring pads or steel wool. Pieces can break off and touch the electrical parts, causing a risk of shock, burns or other personal injury.

Power Cord

A short power-supply cord is used to reduce the hazards resulting from grabbing, entanglement or tripping. **WARNING:** Hot spilled food can cause serious burns.

- **DO** keep appliance and power cord away from children.
- **DO** disconnect the power cord from the electrical outlet when not using the appliance and before cleaning.
- **DO NOT** let the power cord hang over edges of tables or counters.
- **DO NOT** let the power cord touch hot surfaces or open flame, including a stovetop.
- **DO NOT** use below-counter power outlets.
- **DO NOT** use with extension cords, power converters or adapters, timer switches or separate remote-control systems.

⚠ WARNING

This appliance has a polarized plug and one blade is wider than the other. To reduce the risk of electric shock:

- **DO** plug this appliance into a polarized outlet one way.
- **DO** contact a qualified electrician if the plug does not fit in the outlet.
- **DO NOT** attempt to modify the plug. If the plug does not fit full into the outlet, reverse the plug.

Electrical Warning

The cooker base contains electrical components that are an electrical shock hazard. **Failure to follow these instructions may result in electric shock and/or death.**

To protect against electrical shock:

- To disconnect, select **Cancel**, then remove plug from power source. Always unplug when not in use, as well as before adding or removing parts or accessories, and before cleaning. To unplug, grasp the plug and pull from the outlet. **NEVER** pull from the power cord.
- **DO** regularly inspect the appliance and power cord for any signs of damage or fraying.
- **DO NOT** operate the appliance if the power cord or plug is damaged, or after the appliance malfunctions or is dropped or damaged in any manner. For assistance, contact Consumer Care by email at **support@instantpot.com**.
- **DO NOT** attempt to repair, replace or modify components of the appliance, as this may cause electric shock or other personal injury, fire and/or property damage, and will void the warranty. For assistance, contact Consumer Care by email at **support@instantpot.com**.
- **DO NOT** tamper with any of the safety mechanisms, as this may result in personal injury and/or property damage.
- **DO NOT** put liquid or food of any kind into cooker base without the inner cooking pot.
- **DO NOT** immerse the power cord, plug or the appliance in water or other liquid.
- **DO NOT** clean the appliance by rinsing it under a faucet.
- **DO NOT** use the appliance in electrical systems other than 120 V ~ 60 Hz for North America.

SAVE THESE INSTRUCTIONS

⚠ WARNING

Failure to follow safety instructions may result in personal injury and/or property damage and may void your warranty.

WHAT'S IN THE BOX

Pressure Cooking Lid

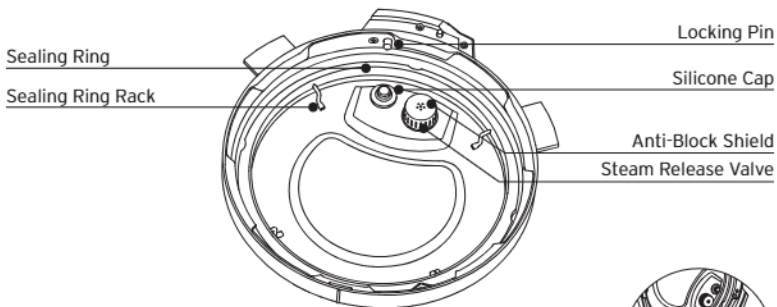
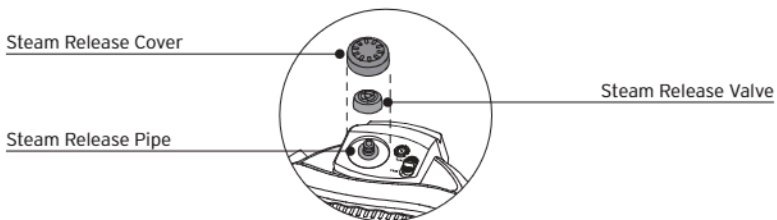
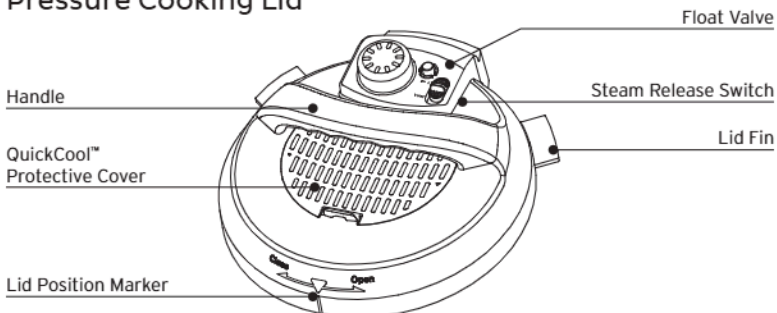

You can insert the left or right lid fin into lid holders on the base to hold the lid and save space.



Illustrations are for reference only and may differ from the actual product.

Air Frying Lid

Top of lid

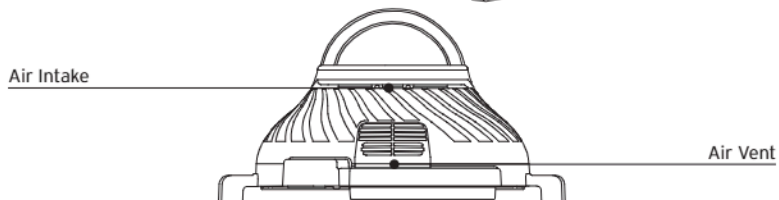
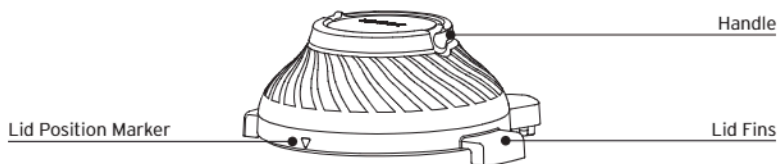

Bottom of lid

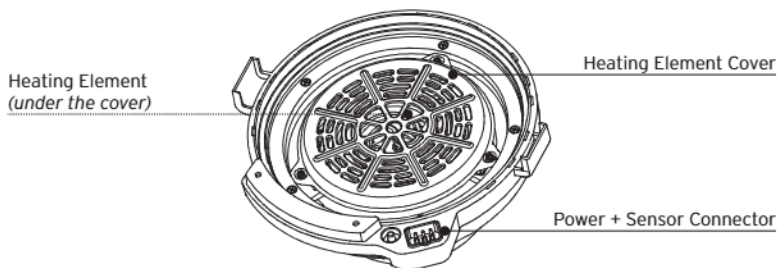

Cooking Pot

Easy-Grip
Silicone Handles

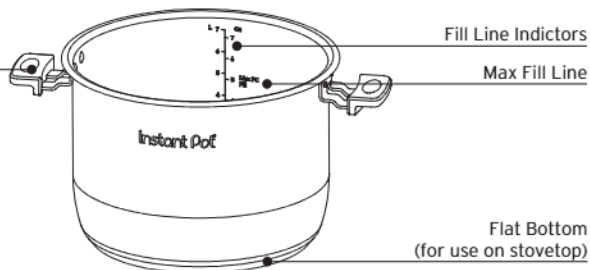

Multi-Cooker Base

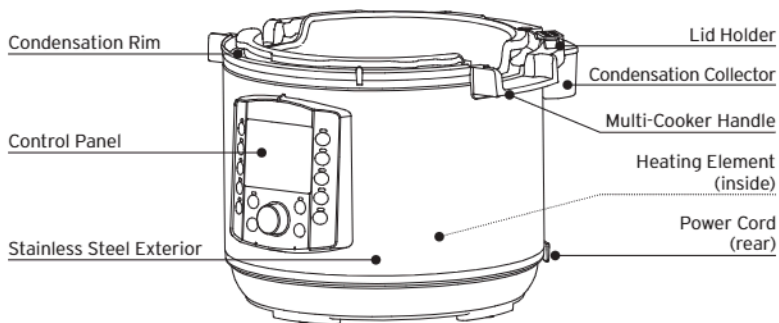

Accessories

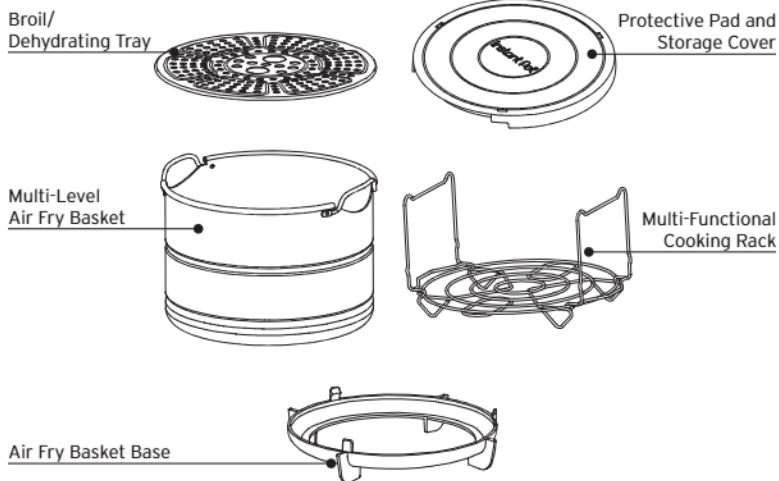

Illustrations are for reference only and may differ from the actual product.

Remember to recycle!

We designed this packaging with sustainability in mind. Please recycle everything that can be recycled where you live.

USING YOUR INSTANT POT PRO CRISP



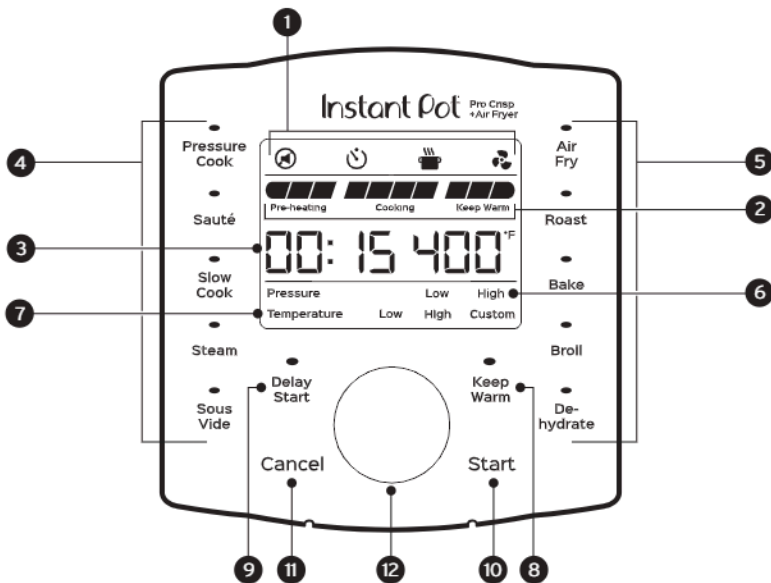

Control panel

We've designed the control panel to be simple to use and easy to read.



1. Status Indicators
2. Progress Bar
 - Shows status at-a-glance
3. Time/Temperature
 - Cooking time
 - Delay Start time
 - Keep Warm time
 - Cooking temperature (Sous Vide)
4. Pressure and Slow Cook smart programs
 - Light shows the active smart program
5. Air Fry smart programs
 - Light shows the active smart program
6. Pressure
 - Low or High pressure
7. Temperature
 - Low, High or Custom temperature
8. Keep Warm On/Off
9. Delay Start On/Off
10. Start
11. Cancel
12. Control Dial

Status indicators

	Sound on
	Sound off
	Delay Start on
	Keep Warm on
	Air fry smart program selected

Status messages

The control panel shows information you need to know when using your Instant Pot Pro Crisp.

OFF	Standby mode
On	Preheat mode
Lid	Lid not properly secured or missing
05:20	Time <ul style="list-style-type: none">• Smart Program: cooking time remaining• Delay Start: time until Smart Program starts• Keep Warm: time food has been warming
Hot	Sauté Smart Program is ready to add food
End	Smart Program ended (Keep Warm is off)
Food burn	Overheating: see Troubleshooting
E*	Error: see Troubleshooting

Delay the start of cooking

You can set a Delay Start timer for the Pressure Cook, Slow Cook and Steam smart programs.

Default Time	Min Time	Max Time
6 hours (06:00)	10 minutes (00:10)	24 hours (24:00)

1. Select a smart program, adjust the settings as you want, then press **Delay Start**.
Once Delay Start has been selected, there is no way to return to the cooking settings. To adjust smart program settings, press Cancel and enter new selections.
2. Turn the **Control Dial** to adjust the delay time, then press the **Control Dial** to set it.
3. Press **Start** to begin.

Turning the sound On/Off

Turn sound on

When in Standby mode, press and hold the **Control Dial** until the sound icon shows ON, then press the **Control Dial** to set it.

Turn sound off

When in Standby mode, press and hold the **Control Dial** until the sound icon shows OFF, then press the **Control Dial** to set it.

Audible safety alerts (beeps) cannot be turned off.

Choosing the temperature scale

You can choose to show cooking temperature in either Fahrenheit or Celsius.

1. Select **Sous Vide** or any **Air Fry** smart program.
2. Press and hold **Control Dial** until the temperature unit flashes. Turn the dial to toggle between °F or °C, then press the **Control Dial** to set it.

Reset smart programs to original settings

Each time you set a smart program to cook, it saves the cooking settings you use, and those become the default the next time you select the program. You can reset them to the original settings.

Reset Individual smart programs

1. With the multi-cooker in Standby mode, press and hold the smart program button you want to reset until the multi-cooker returns to Standby and shows **OFF**.

The smart program's pressure level, cooking time and temperature are restored to the factory default setting.

Reset All smart programs

1. With the multi-cooker in Standby mode, press and hold **Cancel** until the multi-cooker beeps.

All smart program pressure levels, cooking times and temperatures are restored to the factory default setting.

INITIAL SETUP

Clean before use

1. Wash the cooking pot with hot water and soap. Rinse and use a soft cloth to dry the outside. Or you can wash the cooking pot in the dishwasher
2. Wipe the heating element inside the multi-cooker base with a soft cloth to ensure there are no stray packaging particles.
3. Wash the accessories with hot water and dish soap. Rinse with warm, clear water and use a soft cloth to dry.

Assembling the multi-level air fry basket

1. Place the air fry basket base on a stable surface.
2. Position the air fry basket over the base and press down firmly. The teeth on the base should pop into the groove on the outside of the basket.
3. Insert the broil/dehydrating tray into the multi-level air fryer basket, ensuring that the raised rim is facing down.

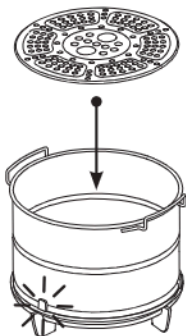

To easily lift and position the tray, hold the large holes in the middle of the tray with 2 fingers.

You must use the air fry basket with the cooking pot.

Connect to power

When you're ready to use your Instant Pot, plug the electrical cord into a power outlet. When you're done cooking and whenever you're cleaning the multi-cooker, unplug the cord from the power outlet.

Test run

Setting up your new Instant Pot Pro Crisp for a test run is a great way to familiarize yourself with how the unit works before you actually cook a meal.

To perform a test run:

1. Add 3 quarts water to the cooking pot.
2. Place the cooking pot into the multi-cooker base.
3. Place the lid on top of the multi-cooker base and lock the lid.
See 'How to close and lock the lid' on page 18.
4. Press **Pressure Cook** on the Control Panel.
5. Use the **Control Dial** to adjust the cooking time to 5 minutes, then press the **Control Dial** to set the time
6. Press **Keep Warm** to turn off the Keep Warm setting.
7. Press **Start** to begin. The message display shows **On**.
8. When cooking is done, the display shows **End**.
9. Release steam by pressing the steam release button until it clicks and locks to the **Vent** position.
See 'How to release steam' below for complete instructions.
10. Unlock and open the lid.
See 'How to unlock and open the lid' on page 19.
11. Discard any remaining water, and then wash and dry the cooking pot.

Now you're ready to cook a meal in your Instant Pot Pro Crisp!

ABOUT PRESSURE COOKING

Pressure cooking uses pressure to raise the temperature in the cooking pot, allowing you to cook food much faster than normal. When pressure cooking, the Instant Pot goes through 3 stages.

Pre-heating

While the multi-cooker pre-heats, it heats the liquid to create steam. Once enough pressure has built up, the lid locks in place and the multi-cooker is ready to start cooking.

Cooking

When the multi-cooker reaches the required pressure level, cooking begins and keeps the pressure level consistent throughout cooking. See the smart program instructions starting on page 24 for details.

Steam release

When food has finished cooking, the multi-cooker is still pressurized and hot. Venting releases the pressure, lowers the temperature and allows you to safely remove the lid.

See How to release steam on page 20.

USING THE PRESSURE COOK LID

You'll use the pressure cook lid for most cooking programs, and especially for pressure cooking. Always use the pressure cook lid that came with this Instant Pot Pro Crisp multi-cooker.

How to close and lock the lid

For pressure cooking, the lid must be securely locked into place to prevent steam from escaping. When you place the lid on the multi-cooker base:

1. Line up the ▼ on the lid with the ⚡ symbol on the multi-cooker base and lower the lid onto the track.

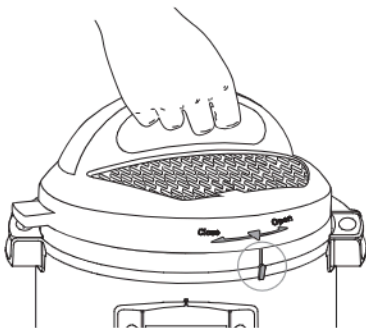

2. Turn the lid until the ▼ on the lid is centered over the control panel.

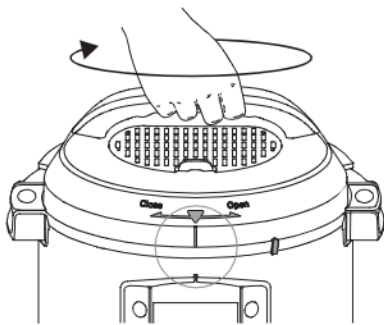

How to unlock and open the lid

Once steam is completely released, you must unlock the lid before opening it:

1. Turn the lid handle to line up the ▼ on the lid with the ⬆ symbol on the multi-cooker base.

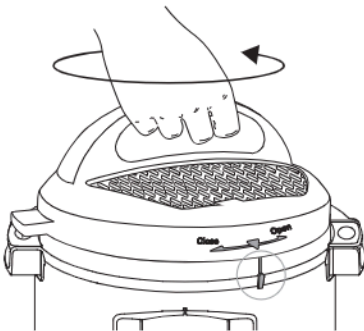

2. Lift the lid up and off the multi-cooker base.

Using liquid to create steam

Pressure cooking requires liquid in the cooking pot to produce the steam needed. Here are the minimum amounts you'll need:

Instant Pot Size	Minimum Liquid for Pressure Cooking*
8 Quarts / 7.6 Litres	1 1/2 cups (12 oz / 375 mL)

**Unless otherwise specified in recipe.*

Pressure cooking liquids should be water-based, such as broth, stock, soup or juice. If using canned, condensed, or cream-based soup, add water as directed above.

How to release steam

Instant Pot Pro Crisp can release steam in 3 different ways: Natural, Quick and Timed release. Use the one that best fits the type of food you're cooking.

Steam release switch

Seal position (closed)

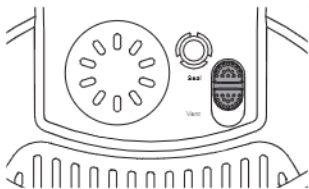

Vent position (open)

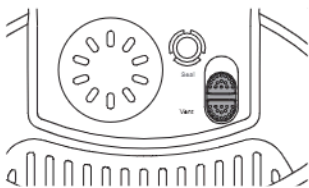

Natural steam release

Releases steam gradually over time (up to 40 minutes or more) after cooking stops.

1. After cooking, leave steam release switch in the **Seal** position until all pressure is released.
2. Float valve drops into lid when all steam is released.
3. After steam release, turn lid counterclockwise and remove the lid.

Quick steam release

Quickly releases steam to stop cooking instantly.

1. After cooking, press the steam release button down until it clicks and locks in the **Vent** position and wait for all pressure to release.
2. The float valve drops into lid when all steam is released.
3. After steam release, turn lid counterclockwise and remove the lid.

Timed steam release

Allows food to continue cooking as steam releases for a specific time that you set.

1. After cooking, leave steam release switch in the **Seal** position for the set time.
2. When the timer reaches 00:00, set steam release switch to **Vent** position and wait for all pressure to release.
3. The float valve drops into lid when all steam is released.
4. After steam release, turn lid counterclockwise and remove the lid.
You can insert the handle into the cooking base vertically for easy storage.

Using the QuickCool Tray

For the fastest Natural Release after pressure cooking (up to 50% faster), you can use the QuickCool Tray, which is sold separately.

The metal portion of the lid gets extremely hot during cooking, so don't remove the QuickCool protective cover unless you're using the QuickCool Tray.

1. Fill the QuickCool Tray with ice or water and freeze it.
2. Once frozen, remove the protective QuickCool protective cover from the pressure cook lid, and position the QuickCool tray on the exposed metal of the lid.
3. When the float valve drops into the lid, remove the QuickCool tray, discard the water and open the lid.

Use caution when removing the tray because some or all of the ice will have melted.

⚠ CAUTION

This appliance uses pressure to cook. Allow the appliance to release all excess pressure and steam before opening the lid. Opening the lid before pressure is released may result in burns, personal injury and/or property damage.

USING THE AIR FRY LID

You'll use the air fry lid for all air frying. Always use the air fry lid that came with this Instant Pot Pro Crisp multi-cooker.

Open the Lid

1. Turn the lid handle to align the ▼ on the lid with the ⬇ symbol on the multi-cooker base.

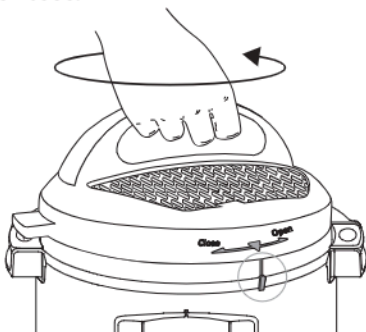

2. Lift the lid up and off the multi-cooker base.

Close the Lid

1. Align the ▼ on the lid with the ⬇ symbol on the multi-cooker base and lower the lid onto the track.

Press the lid down slightly to ensure that the lid sensor connector contacts the base sensor connector.

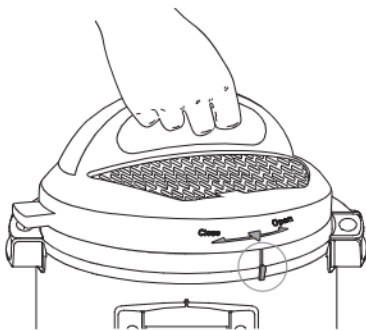

2. Turn the lid until the ▼ on the lid is centered over the control panel.

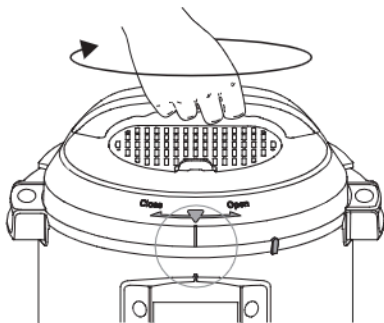

Store the Lid

Use the protective pad to protect the elements on the bottom of the lid during storage.

1. Place the protective pad on the counter with the grooved side facing up.
2. Align the back of the air fryer lid with **OPEN** on the protective pad, then turn the air fryer lid clockwise to the **LOCK** position.

PRESSURE COOK

Pressure cooking uses pressurized steam to quickly and evenly cook foods. Choose from these settings in the Pressure Cook smart program. The program uses the default settings or the settings you selected the last time you used the Pressure Cook program.

Default Time	Time Options	Default Pressure Setting	Pressure Options
35 minutes (00:35)	1 minute (00:01) to 8 hours (08:00)	High	High Low

Other settings

- Automatic Keep Warm is set to ON by default.
- Delay Start is available.

How to pressure cook

Prep

Cut, chop, season or marinate your ingredients according to your recipe.

Preheat

1. Place the cooking pot into the multi-cooker base and add ingredients.
2. Place the pressure cook lid on top of the multi-cooker base and lock the lid.
3. Press **Pressure Cook**.
4. Turn the **Control Dial** to select the cooking time, then press the **Control Dial** to set it.
5. Turn the **Control Dial** to toggle between **High** and **Low** pressure options.
6. Press **Start** to begin. The display shows **On** and the progress bar shows **Pre-heating**.
7. Keep Warm setting is ON by default. Press **Keep Warm** to turn it off.

It can take 10-15 minutes to reach the pressure setting for cooking. Frozen foods increase the preheating time.

The pressure level and time you choose will be the new settings the next time you use the Pressure Cook smart program

Cook

1. When the pressure is ready, cooking starts and the progress bar shows **Cooking**.
2. The cooking timer starts.

You can press Cancel to stop cooking at any time.

Stop cooking

1. When the timer reaches 00:00, cooking stops.
2. If Keep Warm is ON, the timer starts. Press **Cancel** at any time to turn it off.

Release steam

Choose from the steam release method that works for your recipe.

See 'How to release steam' on page 20 for full details.

STEAM

Use Steam as you would a regular stovetop steamer, boiling liquid to cook food with hot steam. Use the multi-functional steam rack to hold food for steaming. The Steam program does not use pressure cooking, even though you'll use the pressure cook lid.

Choose from these settings in the Steam smart program. The program uses the default settings or the settings you selected the last time you used the Steam program.

Default Time	Min Time	Max Time	Temperature
30 minutes (00:30)	1 minute (00:01)	30 minutes (00:30)	Set automatically

Other settings

- Automatic Keep Warm is set to ON by default.
- Delay Start is available.

How to steam

Prep

Cut, chop, season or marinate your ingredients according to your recipe.

Preheat

1. Place the cooking pot into the multi-cooker base and add ingredients.
2. Place the pressure cook lid on top of the multi-cooker base and lock the lid.
3. Press **Steam**.
4. Turn the **Control Dial** to select the cooking time.
5. Press **Start** to begin. The display shows **On** and the progress bar shows **Pre-heating**.

6. Keep Warm setting is ON by default. Press **Keep Warm** to turn it off.
It can take 10-15 minutes to reach the right temperature for cooking. Frozen foods increase the preheating time.
The time you choose will be the new setting the next time you use the Steam smart program.

Cook

1. When the temperature is ready, cooking starts and the progress bar shows **Cooking**.
2. The cooking timer starts.
*You can press **Cancel** to stop cooking at any time.*

Stop cooking

1. When the timer reaches 00:00, cooking stops.
2. If Keep Warm is ON, the timer starts. Press **Cancel** at any time to turn it off.

SAUTÉ

Use Sauté in place of a frying or saucepan. Sautéing can deepen the flavors of your food, or can simmer, thicken or reduce sauces. When using the Sauté program, do not use a lid.

Choose from these settings in the Sauté smart program. The program uses the default settings or the settings you selected the last time you used the Sauté program.

Default Time	Min Time	Max Time	Default Temperature	Temperature Options
30 minutes (00:30)	1 minute (00:01)	1 hour (01:00)	High	Low High Custom (1 to 6)

To help determine what setting to choose, these are the actual temperatures:

Temperature Level	Temperature
High	190°C / 374°F
Low	105°C / 221°F
Custom 1	95°C / 203°F
Custom 2	110°C / 230°F
Custom 3	135°C / 275°F
Custom 4	160°C / 320°F
Custom 5	185°C / 365°F
Custom 6	190°C / 374°F

Other settings

- Automatic Keep Warm is set to OFF by default.
- Delay Start is not available.

How to sauté

Prep

Cut, chop, season or marinate your ingredients according to your recipe.

Preheat

1. Place the cooking pot into the multi-cooker base.
2. Press **Sauté**.
3. Use the **Control Dial** to select **Low**, **High** or **Custom** temperature, then press the **Control Dial** to set it.
4. Use the **Control Dial** to select the cooking time.
5. Press **Start** to begin. The display shows **On** and the progress bar shows **Pre-heating**.

The time and temperature you choose will be the new settings the next time you use the Sauté smart program.

Cook

1. When display shows **Hot**, add ingredients. The progress bar shows **Cooking**.
2. When timer ends, display shows **End**.

*You can press **Cancel** to stop cooking at any time.*

Sautéing before pressure or slow cooking

Quite often, you'll want to sauté foods to brown them before further cooking them.

1. Sauté ingredients.
2. Press **Cancel**.
3. You can deglaze the cooking pot now before switching to **Pressure Cook** or **Slow Cook** (see **Deglazing** below).

Select the smart program you want to use to cook.

Deglazing

Deglazing is the process of adding a liquid to a hot pan, releasing all of the delicious, caramelized pieces stuck to the bottom.

1. Remove food from cooking pot.
2. Add water, broth, or wine.
3. Use wooden spoon or silicone spatula to loosen food stuck to bottom of the cooking pot.

SLOW COOK

Slow Cook lets you make your favorite simmering and stewing recipes, just as you would in a slow cooker. Slow Cook does not use pressure to cook food. Make sure steam release is set to **Vent** or use a glass lid with a venting hole.

Choose from these settings in the Slow Cook smart program. The program uses the default settings or the settings you selected the last time you used the Slow Cook program.

Default Time	Min Time	Max Time	Default Temperature	Temperature Options
4 hours (04:00)	30 minutes (00:30)	24 hours (24:00)	High	Low High

Other settings

- Automatic Keep Warm is set to ON by default.
- Delay Start is not available.

Temperature settings

For Slow Cooking, you can choose either the Low or High setting.

High Setting	Low Setting
<ul style="list-style-type: none">• 2.5 hours to reach maximum temperature of 203°F/95°C (faster)• 3 hours minimum cooking time recommended• Faster initial heating is ideal for foods like leaner meats (chicken or pork), soft vegetables and soups	<ul style="list-style-type: none">• 3.5 hours to reach maximum temperature of 203°F/95°C (slower)• 4 hours minimum cooking time recommended• Slower initial heating is ideal for foods like tougher meats (pot roast or brisket), dense roasts, bone in meat and root vegetables

How to slow cook

Prep

Cut, chop, season or marinate your ingredients according to your recipe.

Cook

1. Place the cooking pot into the multi-cooker base.
2. Add ingredients to the cooking pot.
3. Place pressure cook lid on top of the multi-cooker base and lock the lid.
4. Press **Slow Cook**.
5. Use the **Control Dial** to select **Low** or **High** temperature, then press the **Control Dial** to select it.
6. Use the **Control Dial** to select the cooking time.
7. Press **Start** to begin. The display shows **On** and the progress bar shows **Pre-heating**
8. **Keep Warm** setting is **On** by default. Press **Keep Warm** again to turn it off.
9. When the unit reaches the correct cooking settings, the progress bar shows **Cooking**.

The time and temperature you choose will be the new settings the next time you use the Slow Cook smart program.

Keep Warm

When cooking completes, the display shows **End** if **Keep Warm** is turned off. If not, the timer begins counting from **00:00** up to **10 hours (10:00)**.

SOUS VIDE

Sous Vide cooks food underwater in an air-tight, food-safe bag, for a long period of time. Food cooks in its own juices and comes out delicious and very tender. Sous Vide does not use pressure to cook food.

Choose from these settings in the Sous Vide smart program. The program uses the default settings or the settings you selected the last time you used the Slow Cook program.

Default Time	Min Time	Max Time	Default Temperature	Temperature Options
3 hours (03:00)	30 minutes (00:30)	99 hours, 30 minutes (99:30)	60°C / 140°F	Min: 25°C / 77°F Max: 95°C / 203°F

Other settings

- Automatic Keep Warm is not available.
- Delay Start is not available.

What you need to sous vide

- Tongs
- Food safe, airtight, re-sealable food pouches

OR

- Vacuum sealer and food-safe vacuum bags

How to sous vide

Prep

1. Cut, chop, season or marinate your ingredients according to your recipe.
2. Add the ingredients to the cooking bag or pouch and seal tightly.

Preheat

1. Fill the cooking pot with water to the [1/2] mark.
2. Place the cooking pot into the multi-cooker base.
3. Place the lid on top of the multi-cooker base and lock the lid.
4. Press **Sous Vide**.
5. Turn the **Control Dial** to select the time, then press the **Control Dial** to select it.
6. Turn the **Control Dial** to select the temperature.
7. Press **Start**. The display shows On and the progress bar shows **Pre-heating**.

The time and temperature you choose will be the new settings the next time you use the Sous Vide smart program.

Cook

1. When the Progress Bar shows **Add Food**, open the lid, add the cooking bag or pouch to the cooking pot, then close the lid again. The cooking time starts counting down.
2. When the cooking time reaches 00:00, the Message Bar shows End. *You can press **Cancel** to stop cooking at any time.*

Remove food

1. When cooking is done, press the steam release button down until it clicks and locks in the **Vent** position and wait for all pressure to release.
2. Remove the lid and use the tongs to carefully remove the cooking pouch.

KEEP WARM

The Keep Warm setting turns on automatically after cooking on most smart programs. You can also use Keep Warm to reheat food.

Choose from these settings in the Keep Warm smart program. The program uses the default settings or the settings you selected the last time you used the Keep Warm program.

Default Time	Min Time	Max Time	Keep Warm Temperature	Reheat Temperature Options
10 hours (10:00)	30 minutes (00:30)	10 hours (10:00)	High	Low High Custom (see below)

Custom Temperature Settings

- Min: 77° F / 25° C
- Max: 203° F / 95° C

How to keep warm after cooking

1. When cooking is finished, automatic warming begins. The timer shows the time passed, up to 10 hours.
2. To turn Keep Warm off at any time, press **Cancel**.

How to reheat

Prep

Place the food to be reheated into the cooking pot or into an oven-safe baking dish that fits in the cooking pot.

Reheat

1. Place the cooking pot into the multi-cooker base.
2. If you're using a baking dish, fill the bottom of the cooking pot with 1-1/2 cups water, place the multi-functional rack into the cooking pot, and place the baking dish on top of the rack.

3. Place the lid on top of the multi-cooker base and lock it.
4. Press **Keep Warm**.
5. Press the **Control Dial** to cycle through **Low**, **High** and **Custom** temperature levels, then press the **Control Dial** to select it.
6. If you chose Custom temperature, turn the **Control Dial** to set the specific temperature, then press the **Control Dial** to select it.
7. Use the **Control Dial** to select the cooking time.
8. Use the **Control Dial** to select the cooking time.
9. Press **Start** to begin.

The time and temperature you choose will be the new settings the next time you use the Keep Warm smart program to reheat.

AIR FRY

Instant Pot Pro Crisp uses the Air Fry lid to produce rapid air circulation to crisp or cook food, giving your meals all the rich, crispy flavor of deep frying, with little to no oil.

How to cook with Air Fry

- Cook your dish entirely with the Air Fry, Roast, Bake, Broil or Dehydrate smart programs.
- Give your food a crisp finish after cooking with the Pressure Cook, Slow Cook, Steam or Sous Vide smart programs.

What to cook in

You can use the multi-level air fry basket, the cooking pot or add the broil/dehydrating tray, depending on the results you are trying to achieve.

Place food	Results
Directly in the cooking pot	Golden and crispy on top, but moist on the bottom. Good for broiled chicken.
On the bottom of the multi-level air fry basket	Golden and crispy on the top and sides. Good for french fries.
On the bottom of the multi-level air fry basket, and cover with the broil/dehydrating tray	Less crisp. Use for dehydrating.
On the broil/dehydrating tray in the multi-level air fry basket	Places food closer to the heating unit for faster results. Use for melting cheese or giving cooked food a crisp, golden finish.

Choose from these settings in the Air Fry smart program. The program uses the default settings or the settings you selected the last time you used the Air Fry program.

Setting	Default	Minimum	Maximum
Temperature	400°F / 204°C	180°F / 82°C	450°F / 232°C
Cooking Time	18 minutes (00:18)	1 minute (00:01)	1 hour (01:00)

Prep

Cut, chop, season, marinate or batter your ingredients according to your recipe.

Cook

1. Place your food into the air fry basket and then place the air fry basket into the cooking pot.
2. Insert the cooking pot into the multi-cooker base.
3. Place the lid on the multi-cooker base.
4. Press **Air Fry**.
5. Turn the **Control Dial** to select the time, then press the **Control Dial** to select it.
6. Turn the **Control Dial** to select the temperature.
7. Press **Start**. The display shows **On** and the progress bar shows **Pre-heating**.

The time and temperature you choose will be the new settings the next time you use the Air Fry smart program.

Turn

For the Air Fry and Roast smart programs:

1. Part way through the cooking cycle the display shows **Turn Food**.
*Some food does not require turning. If you do not remove the lid after **Turn Food** displays, cooking will proceed after 10 seconds.*
2. Lift the air fry lid off the multi-cooker base and place it on the protective pad.
*Lifting the lid automatically pauses cooking. If you do not replace the lid within 3 minutes, the unit returns to Standby mode and the display shows **OFF***
3. Carefully turn, flip, or rotate your food.
4. Replace the lid on the multi-cooker base. Cooking continues.

Finish

- When the smart program completes, the lid beeps, and the display shows **End**.

The air fry lid beep after 5 minutes, 20 minutes, and 60 minutes to remind you that cooking has completed.

ROAST

You can roast foods like beef, lamb, pork, poultry, vegetables and scalloped potatoes, for a deliciously tender inside and browned outside.

Setting	Default	Minimum	Maximum
Temperature	380°F / 193°C	180°F / 82°C	400°F / 232°C
Cooking Time	40 minutes (00:40)	1 minute (00:01)	1 hour (01:00)

To roast

- Follow the basic instructions for Air Frying.
- Select “Roast” as the smart program.

BAKE

You can use Bake to cook foods like cheesecake, pudding cake, baked fruits and cobblers.

Setting	Default	Minimum	Maximum
Temperature	365°F / 185°C	180°F / 82°C	400°F / 232°C
Cooking Time	30 minutes (00:30)	1 minute (00:01)	1 hour (01:00)

To bake

- Follow the basic instructions for Air Frying.
- Select “Bake” as the smart program.
- There is no need to turn the food partway through cooking.

Leave approximately 1”/ 2.5 cm of space around all sides of the baking dish to allow heat to circulate evenly.

BROIL

Broiling cooks using direct top-down heating, and broiled foods are best when placed close to the heating element.

Setting	Default	Minimum	Maximum
Temperature	450°F / 232°C	Not adjustable	Not adjustable
Cooking Time	6 minutes (00:06)	1 minute (00:01)	40 minutes (00:40)

To broil

- Follow the basic instructions for Air Frying.
- Place food in the broil/dehydrating tray in the air fryer basket.
- Select “Broil” as the smart program.
- There is no need to turn the food partway through cooking.

DEHYDRATE

Dehydrating uses low heat over a long period of time to safely dry out food items, like dried fruit, jerky and dried veggies.

Setting	Default	Minimum	Maximum
Temperature	125°F / 52°C	105°F / 41°C	165°F / 74°C
Cooking Time	7 hours (07:00)	1 hour (01:00)	72 hours (72:00)

To dehydrate

- Follow the basic instructions for Air Frying.
- Place food in the broil/dehydrating tray in the air fryer basket.
- Select “Dehydrate” as the smart program.
- There is no need to turn the food partway through cooking.

MAINTENANCE

Your Instant Pot Pro Crisp includes parts that enable pressure cooking. These parts must be installed for pressure cooking to work properly and either cleaned or replaced regularly.

⚠ WARNING

Failure to follow safety instructions may result in personal injury and/or property damage and may void your warranty.

Sealing Ring

When the pressure cook lid is closed, the sealing ring installed on the underside of the lid creates an air-tight seal between the lid and the multi-cooker base.

- The sealing ring must be installed before using the multi-cooker and should be cleaned after each use.
- Install 1 sealing ring at a time; use one for sweet dishes and one for savory.
- Sealing rings stretch over time with normal use. To keep your product safe, replace the sealing ring every 12 to 18 months. Replace sooner if you notice stretching, deformation, or damage.

Install the Sealing Ring

1. Place the sealing ring over the sealing ring rack and press it into place. Press down firmly to ensure there is no puckering.
2. The sealing ring should be snug and should not fall out when the lid is turned over.

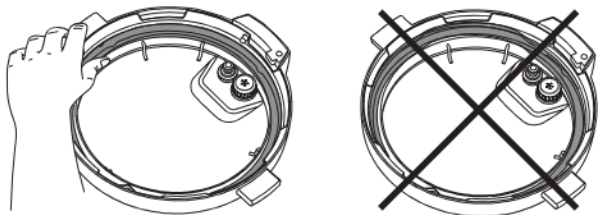

Remove the Sealing Ring

1. Grip the edge of the sealing ring and pull it out from behind the sealing ring rack.
2. Inspect the rack to ensure it is secured, centered, and an even height all the way around the lid. If the sealing ring rack is deformed, do not try to repair it.

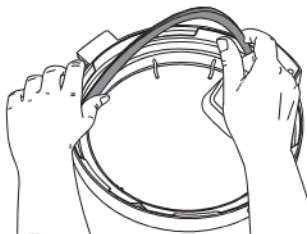

Steam release assembly

When the multi-cooker releases pressure, steam ejects from the top of the steam release assembly. The steam release assembly is integral to product safety and necessary for pressure cooking. It must be installed before use and cleaned regularly.

Steam Release Cover



Steam Release Valve



Steam Release Pipe

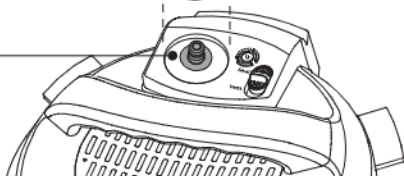

Remove the steam release valve and cover

1. Pull the steam release cover up and off.
2. Pull the steam release valve up and off the steam release pipe.

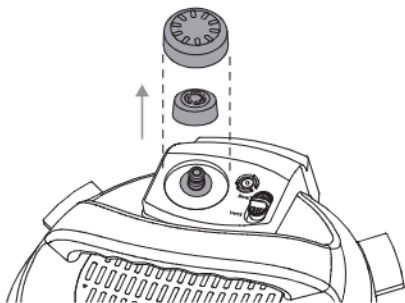

Install the steam release valve and cover

1. Place the steam release valve on the steam release pipe.
2. Place the steam release cover on the steam release valve and press down firmly.

The steam release valve must be installed before using the multi-cooker.

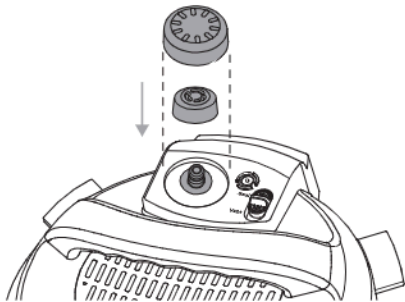

Float valve and silicone cap

The float valve shows when there is pressure in the multi-cooker (float valve up) or when steam is fully released and it is safe to open the lid (float valve down).

Remove the float valve from the lid

1. Place one finger on the flat top of float valve, then turn the lid over. Detach the silicone cap from the bottom side of the float valve.

Top of Lid



Bottom of Lid

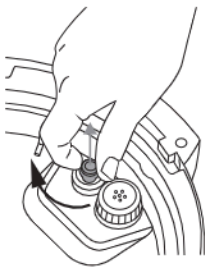

2. Remove the float valve from the top of the lid. Do not discard the float valve or silicone cap.

Install the float valve

- Drop the narrow end of the float valve into the float valve hole on the top of the lid. Place one finger on the flat top of the float valve, then turn the lid over. Firmly attach the silicone cap to the bottom of the float valve.
- Do not attempt to operate the pressure cooker without the float valve and/or silicone cap properly installed in the pressure cook lid.

Anti-Block Shield

The anti-block shield prevents food particles from coming up through the steam release pipe, helping to regulate pressure.

As an integral part of product safety, the anti-block shield must be installed before use and cleaned frequently.

Remove the anti-block shield

- Turn the pressure cook lid over and hold it securely with one hand. Use the other hand to grasp the anti-block shield with your fingers and pull firmly to remove it from the prongs underneath.



Install the anti-block shield

- Place anti-block shield over prongs and press down until it snaps into position. Do not attempt to operate the multi-cooker for pressure cooking without the anti-block shield installed.

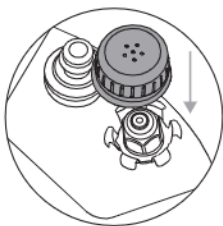

Condensation collector

The condensation collector sits at the back of the multi-cooker base and accumulates overflow moisture from the condensation rim. It should be installed before cooking, then emptied and rinsed out after each use.

Install the condensation collector

- Align the grooves on the condensation collector with the tabs on the back of the multi-cooker base and slide the condensation collector into place.

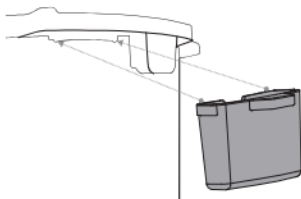

Remove the condensation collector

- Pull the condensation collector away from the multi-cooker base; do not pull down.

Note the tabs on the multi-cooker base and the grooves on the condensation collector.

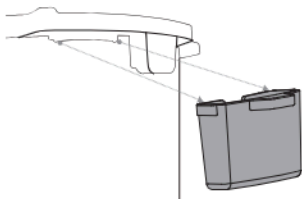

QuickCool protective cover

The protective cover protects the lid when you're not using the QuickCool Tray (sold separately) for steam release. See page 21 for instructions on how to use the QuickCool Tray.

Install the protective cover

- Grip the tab and slide the cover towards the back of the metal portion of the lid, then press down until it clicks.

Remove the protective cover

- Grip the tab and push it towards the lid handle, then pull it up, towards you, and off.

CLEANING

Clean your Instant Pot Pro Crisp after each use. Always unplug the unit and let all parts cool to room temperature before cleaning. Before use or storing, make sure all surfaces are dry.

Part	Cleaning instructions
<p>Pressure Cooker Lid and parts</p> <ul style="list-style-type: none">• Anti-Block Shield• Sealing Ring• Steam Release Valve• Float Valve• Silicone Cap• Condensation Collector	<ul style="list-style-type: none">• Hand wash with hot water and mild dish soap or wash in dishwasher, top rack.• Remove all small parts from lid before washing.• With steam release valve and anti-block shield removed, clean interior of steam release pipe to prevent clogging.• To drain water from the lid after dishwashing, grasp the lid handle and hold the lid vertically over a sink, then turn it all the way around.• After cleaning, store the lid upside down on the multi-cooker base.• Store sealing rings in a well-ventilated area to disperse odor.• To eliminate odors from sealing ring, add 1 cup (8 oz / 250 mL) water and 1 cup (8 oz / 250 mL) white vinegar to cooking pot, and run Pressure Cook for 5-10 minutes, then use Quick Steam Release.• Empty and rinse condensation collector after each use.
<p>Air Fryer Lid</p>	<ul style="list-style-type: none">• Allow the air fry lid to cool to room temperature, then clean the heating element and surrounding area with a soft, damp cloth or sponge. Ensure it is free of food debris and/or grease splatter.• Wipe the exterior clean with a soft damp cloth or sponge.• Do not remove the heating element cover.

Part	Cleaning instructions
Inner Cooking Pot	<ul style="list-style-type: none"> • Wash after each use. • Hand wash with hot water and mild dish soap or wash in dishwasher*. • Hard water stains may need a vinegar-dampened sponge and scrubbing to remove. • For tough or burned food residue, soak in hot water for a few hours before cleaning. • Dry all exterior surfaces before placing in multi-cooker base.
Accessories <ul style="list-style-type: none"> • Steam Rack • Protective Pad and Storage Cover • Multi-Level Air Fry Basket • Air Fry Basket Base • Multi-Functional Rack • Broil/Dehydrating Tray 	<ul style="list-style-type: none"> • Wash after each use. • Hand wash with hot water and mild dish soap or wash in dishwasher, top rack. • Never use harsh chemical detergents, powders or scouring pads on accessories.
Power Cord	<ul style="list-style-type: none"> • Use a barely-damp cloth to wipe any particles off cord.
Multi-Cooker Base	<ul style="list-style-type: none"> • Wipe the inside of the multi-cooker base as well as the condensation rim with a barely-damp cloth, and allow to air dry. • Clean the outside of the multi-cooker base and the control panel with a soft, barely-damp cloth or sponge.

**Some discoloration may occur after machine washing, but this will not affect the multi-cooker's safety or performance.*

TROUBLESHOOTING

Problem	Cause	Solution
Air fryer lid is in place but will not turn on	The connection between the air fry lid and pressure cooker base is loose or broken.	Make sure the Air Fryer Lid is seated correctly on the pressure cooker base.
	Bad power connection or no power.	Inspect the power cord and make sure it is pushed firmly into the multi-cooker base.
	Electrical fuse has blown.	Contact Consumer Care.
	Microswitch is dirty grease or damaged.	Contact Consumer Care.
Black smoke is coming from the air fry lid	Using an oil with a low smoke point.	Cancel the smart program, unplug the multi-cooker and allow it to cool to room temperature. Choose a neutral oil with a high smoke point, such as Canola, Avocado, Soybean, Safflower, or Rice Bran.
	Food residue on the bottom of the cooking pot or around the element on the air fry lid.	Cancel the smart program, unplug the multi-cooker and allow it to cool to room temperature. Remove all accessories from the cooking pot and clean the cooking pot, air fry lid, and all accessories thoroughly.
	Appliance malfunction.	Contact Consumer Care.
White Smoke is coming from the air fry lid	Cooking foods with a high fat content, such as bacon, sausage, and hamburger.	Avoid air frying foods with a high fat content. Check the cooking pot for excess oil and/or fat and carefully remove as needed before air frying.
	Food is moist.	As water in the food is vaporized it turns to steam and escapes the multi-cooker. Pat dry moist food ingredients before air frying.
	Seasoning on food has blown into element.	Be mindful when seasoning food. Spray vegetables and meats before adding seasoning so they adhere to the ingredients.

Problem	Cause	Solution
Difficulty closing pressure cook lid	Sealing ring not properly installed.	Reposition sealing ring, ensure it is snug behind sealing ring rack.
	Float valve in the popped-up position.	Gently press the float valve downward with a long utensil.
	Contents in multi-cooker are still hot.	Set the steam release switch to the Venting position, then lower lid onto multi-cooker base slowly, allowing heat to dissipate.
Difficulty opening pressure cook lid	Pressure inside the multi-cooker.	Release pressure according to recipe; only open lid after float valve has dropped down.
	Float valve obstructed by food debris or residue.	Make sure the steam release switch is set to the Venting position, then press float valve gently with a long utensil. Open lid cautiously and thoroughly clean float valve, surrounding area, and lid before next use.
Cooking pot is stuck to lid when cooking is finished	Cooling of cooking pot may create suction, causing cooking pot to adhere to the lid.	To release the vacuum, set the steam release switch to the Venting position.
Steam leaks from side of lid	No sealing ring in lid.	Install sealing ring.
	Sealing ring damaged or not properly installed.	Replace sealing ring.
	Food debris attached to sealing ring.	Remove sealing ring and clean thoroughly.
	Lid not closed properly.	Open, then close lid.
	Sealing ring rack is warped or off-center.	Remove sealing ring from lid, check sealing ring rack for bends or warps. Contact Consumer Care.
	Inner cooking pot rim may be misshapen.	Check for deformation and contact Consumer Care.

Problem	Cause	Solution
Float valve does not rise	Food debris on float valve or float valve silicone cap.	Remove float valve from lid and clean thoroughly. Perform Initial Test Run to check for function. Record findings and contact Consumer Care.
	Too little liquid in the cooking pot.	Check for scorching on bottom of cooking pot. Add thin, water-based liquid to the cooking pot according to its size: 6 Quart: 1 1/2 cups (12 oz / 375 mL) 8 Quart: 2 cups (16 oz / 500 mL)
	Float valve silicone cap damaged or missing.	Install silicone cap or replace float valve entirely.
	Float valve obstructed by lid-locking mechanism.	Tap float valve with a long utensil. If the float valve does not drop, turn the multi-cooker off. Contact Consumer Care.
	No heat in the cooking pot.	Perform Initial Test Run to check for function and record findings. Contact Consumer Care.
	Cooking pot base may be damaged.	Perform Initial Test Run to check for function and record findings. Contact Consumer Care.
Minor steam leaking/hissing from steam release valve during cook cycle	Quick release button not in Seal position.	Check the steam release switch to ensure it's in the Seal position.
	Multi-cooker is regulating excess pressure.	This is normal; no action required.
Steam gushes from steam release valve when quick release button is in Seal position	Not enough liquid in the cooking pot.	Add thin, water-based liquid to the cooking pot according to its size: 6 Quart: 1 1/2 cups (12 oz / 375 mL) 8 Quart: 2 cups (16 oz / 500 mL)
	Pressure sensor control failure.	Contact Consumer Care.
	Steam release valve not seated properly.	Check the steam release switch to ensure it's in the Seal position.

Problem	Cause	Solution
Display remains blank after connecting the power cord	Bad power connection or no power.	Inspect power cord for damage. If damage is noticed, contact Consumer Care. Check outlet to ensure it is powered.
	Multi-cooker's electrical fuse has blown.	Contact Consumer Care.
Occasional clicking or light cracking sound	The sound of power switching and expanding pressure board when changing temperatures.	This is normal; no action needed.
	Bottom of the cooking pot is wet.	Wipe exterior surfaces of cooking pot. Ensure heating element is dry before inserting cooking pot into multi-cooker base.
Error code appears on display and multi-cooker beeps continuously	There is an issue with the multi-cooker.	Read "Error Codes" on page 53 for instructions.

ERROR CODES





If the control panel displays an error code from this list, there is an issue with the Pro Crisp. Here are the actions you should take to fix the problem.

Problem	Cause	Solution
C1 C2 C6 C6H C6L	Faulty sensor.	Contact Consumer Care.
C5	Temperature is too high because cooking pot is not placed in the multi-cooker base.	Press Cancel and wait for heating element to cool; ensure there are no foreign objects in multi-cooker base; insert or reposition cooking pot in multi-cooker base and re-enter commands.
C5	Temperature is too high because there is no water in cooking pot.	Check for scorching on bottom of cooking pot. Add thin, water-based liquid to the cooking pot according to its size: 3 Quart: 1 cup (8 oz / 250 mL) 6 Quart: 1 1/2 cups (12 oz / 375 mL) 8 Quart: 2 cups (16 oz / 500 mL)
C7 or NoPr	Not enough liquid.	Add thin, water-based liquid to the cooking pot according to its size: 3 Quart: 1 cup (8 oz / 250 mL) 6 Quart: 1 1/2 cups (12 oz / 375 mL) 8 Quart: 2 cups (16 oz / 500 mL)
C7 or NoPr	Quick release button is in the Vent position.	Check Steam Release switch to ensure it's set to Seal.
C9	Sensor connectors on Air Fryer Lid and multi-cooker base are not making full contact.	Press the lid down slightly to ensure that the lid sensor connector contacts the base sensor connector.
Lid	Lid is not in the correct position for the selected program.	Open and close the lid. Do not use a lid when using Sauté.
Pot	Cooking pot is missing from the multi-cooker base.	Insert the cooking pot into the multi-cooker base and try again. If the error code appears while the cooking pot is in the multi-cooker base, contact Consumer Care.

Problem	Cause	Solution
Food burn	High temperature detected at bottom of cooking pot; multi-cooker automatically reduces temperature to avoid overheating.	Starch deposits at the bottom of the cooking pot may have blocked heat dissipation. Turn the multi-cooker off, release pressure according to the recipe, and inspect the bottom of the cooking pot.
PrSE	Pressure has accumulated during a non-pressure cooking program.	Set Steam Release switch to Vent.

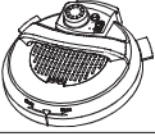
REPLACEMENT PARTS

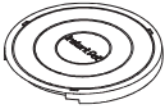
We offer genuine replacement parts for your Instant Pot® Pro Crisp, if you need them. Visit www.instantpot.com to order.

	Part	Part number
	Pressure Cooker Lid	310-0111-01
	Air Fry Lid	310-0109-01
	Protective Pad	310-0112-01
	Steam Release Cover	310-0114-01
	Condensation Collector	310-0113-01
	User Manual	399-1282-03US

LEARN MORE

There's a whole world of Instant Pot® cooking information and help just waiting for you. Here are some of the most helpful resources.

Register your product

Instantpot.com/register

Contact Consumer Care

In the Instant Connect™ App

Instantpot.com/customer-care-center
support@instantpot.com

Download the Instant Connect™ App

Discover guided cooking and recipes

Available at iOS and Android app stores

Cooking charts and more recipes

Instantpot.com

How-to videos, tips and more

Instantpot.com

Replacement parts and accessories

Instantpot.com

Join the community



Product specifications

Model	Volume	Wattage	Power
Pro Crisp AF 8	8 Quarts 7.6 Litres	1500 watts	120V ~ 60Hz

WARRANTY

One (1) Year Limited Warranty

This One (1) Year Limited Warranty applies to purchases made one year from the purchase date or delivery date, whichever is later, from authorized retailers of Instant Pot Brands by the original appliance owner and is not transferable. Proof of original purchase date and, if requested by Instant Pot Brands, return of your appliance, is required to obtain service under this Limited Warranty. Provided the appliance was used in accordance with the use & care instructions, Instant Pot Brands will, in its sole and exclusive discretion, either: (i) repair defects in materials or workmanship; or (ii) replace the appliance. In the event that your appliance is replaced, the Limited Warranty on the replacement appliance will expire twelve (12) months from the date of receipt. Failure to register your product will not reduce your warranty rights. The liability of Instant Pot Brands, if any, for any allegedly defective appliance or part will not exceed the purchase price of a comparable replacement appliance.

What is not covered by this warranty?

- Products purchased, used, or operated outside of the United States and Canada.
- Products that have been modified or attempted to be modified.
- Damage resulting from accident, alteration, misuse, abuse, neglect, unreasonable use, use contrary to the operating instructions, normal wear and tear, commercial use, improper assembly, disassembly, failure to provide reasonable and necessary maintenance, fire, flood, acts of God, or repair by anyone unless directed by an Instant Pot Brands representative.
- Use of unauthorized parts and accessories.
- Incidental and consequential damages.
- The cost of repair or replacement under these excluded circumstances.

EXCEPT AS EXPRESSLY PROVIDED HEREIN AND TO THE EXTENT PERMITTED BY APPLICABLE LAW, INSTANT POT BRANDS MAKES NO WARRANTIES, CONDITIONS OR REPRESENTATIONS, EXPRESS OR IMPLIED, BY STATUTE, USAGE, CUSTOM OF TRADE OR OTHERWISE WITH RESPECT TO THE APPLIANCES OR PARTS COVERED BY THIS WARRANTY, INCLUDING BUT NOT LIMITED TO, WARRANTIES, CONDITIONS, OR REPRESENTATIONS OF WORKMANSHIP, MERCHANTABILITY, MERCHANTABILITY, FITNESS FOR A PARTICULAR PURPOSE OR DURABILITY.

Some states or provinces do not allow for: (1) the exclusion of implied warranties of merchantability or fitness; (2) limitations on how long an implied warranty lasts; and/or (3) the exclusion or limitation of incidental or consequential damages; so these limitations may not apply to you. In these states and provinces, you have only the implied warranties that are expressly required to be provided in accordance with applicable law. The limitations of warranties, liability, and remedies apply to the maximum extent permitted by law. This limited warranty gives you specific legal rights, and you may also have other rights which vary from state to state or province to province.

Product Registration

Please visit www.instantpot.com/register to register your new Instant Pot Brands appliance. Failure to register your product will not diminish your warranty rights. You will be asked to provide the store name, date of purchase, model number (found on the back of your appliance) and serial number (found on the bottom of your appliance) along with your name and email address. The registration will enable us to keep you up to date with product developments and recipes, and contact you in the unlikely event of a product safety notification. By registering, you acknowledge that you have read and understand the instructions for use, and warnings set forth in the accompanying instructions.

Warranty Service

To obtain warranty service, please contact our Consumer Care Department by email to support@instantpot.com. You can also create a support ticket online at www.instantpot.com. If we are unable to resolve the problem, you may be asked to send your appliance to the Service Department for quality inspection. Instant Pot Brands is not responsible for shipping costs related to warranty service. When returning your appliance, please include your name, mailing address, email address, phone number, and proof of the original purchase date as well as a description of the problem you are encountering with the appliance.

⚠ WARNING

DO NOT place this appliance on or close to a gas or electric burner, or inside an oven. **NEVER** use on your stove. Always operate this appliance on a stable, non-combustible, level surface, such as a kitchen countertop.



In Canada, distributed by
Instant Pot Brands
199 Bay Street, Suite 4000
Toronto, ON M5L 1A9 Canada

In U.S., distributed by
Instant Pot Brands
8725 W Higgins Road, Suite 725
Chicago, IL 60631 U.S.

instantpot.com

© 2025 Instant Pot Brands
399-1282-03US

Art release date
07/16/2025

INSTANT POT
is a registered trademark
of Instant Pot Brands